

# LINEMAN ASSEMBLY INSTRUCTIONS

SEE BACK FOR EXPLODED VIEW OF ASSEMBLY OPTIONS.

**DO NOT ASSEMBLE TOP AND BOTTOM TOGETHER UNTIL ALL OTHER OPTIONS HAVE BEEN ASSEMBLED AS PARTS ARE DESIGNED AS A ONE TIME SNAP TOGETHER ASSEMBLY.**

**CAUTION: BE SURE LAMP FITS THROUGH BOTTOM OPENING, IF NOT ASSEMBLE TOP AFTER BOTTOM, LAMP, AND OPTIONAL LITELID HAVE BEEN INSTALLED IN FITTER.**

**A.L.P. DOES NOT RECOMMEND USING LAMPS WITH A DIAMETER ABOVE 7.25 INCHES**

- 1) CAP TO TOP WITHOUT FINIAL: SEE FIGURE 1 FOR ASSEMBLY ILLUSTRATION.
- 2) TOP WITH FINIAL (NO CAP): SEE FIGURE 2 FOR ASSEMBLY ILLUSTRATION.
- 3) CAP TO TOP WITH FINIAL: SEE FIGURE 3 FOR ASSEMBLY ILLUSTRATION.
- 4) NECK RING (OPTIONAL): PLACE NECK RING OVER BOTTOM NECK AND SECURE WITH FASTENERS IN FITTER. SEE FIGURE 3.
- 5) LITELID (OPTIONAL): PLACE LITELID INTO BOTTOM, WITH RAISED SIDE FACING UP. SEE FIGURE 3.
- 6) ASSEMBLE TOP TO BOTTOM: ALIGN ROUND PEGS ON TOP TO VERTICAL "L" SLOTS ON BOTTOM. SET TOP ONTO BOTTOM UNTIL TOP TOUCHES THE RIM OF THE BOTTOM. ROTATE TOP CLOCKWISE UNTIL VERTICAL RIBS ENGAGE INTO BOTTOM'S VERTICAL ANTI-ROTATION SLOTS.

FIGURE 1.  
CAP WITHOUT  
FINIAL

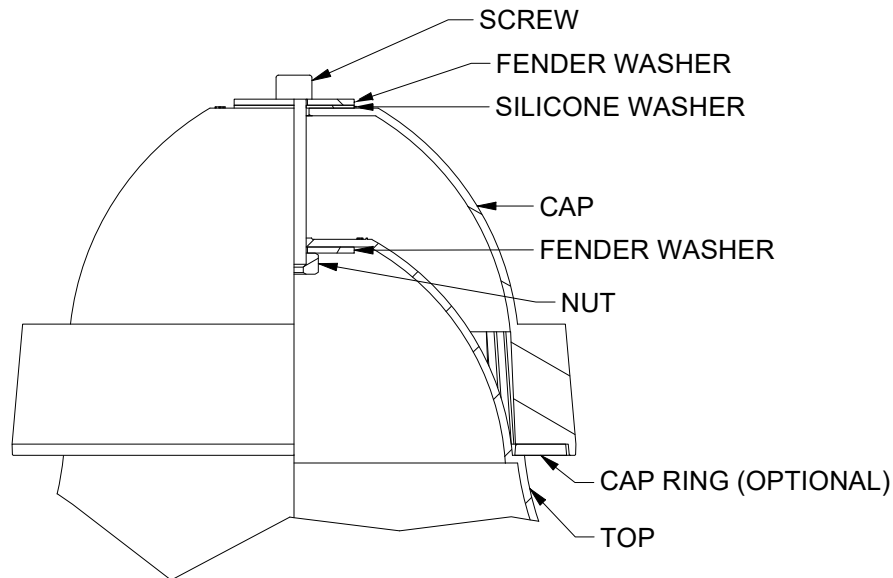

FIGURE .2  
TOP WITH FINIAL  
(NO CAP)

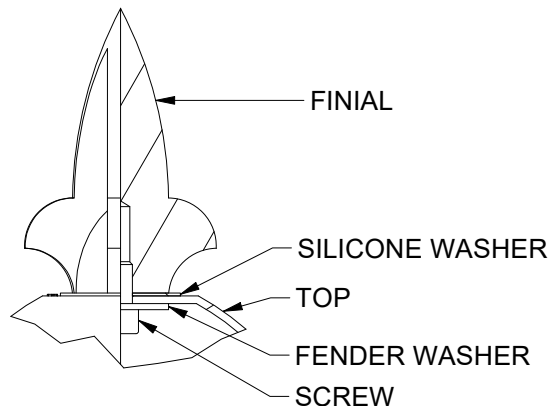

FIGURE 3.  
TOP, CAP, AND FINIAL

