

PROPRIETARY DESIGN AND ENGINEERING
 RESTRICTED INFORMATION
LUXALITE
 4042-1000000000

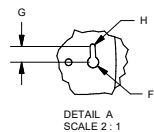
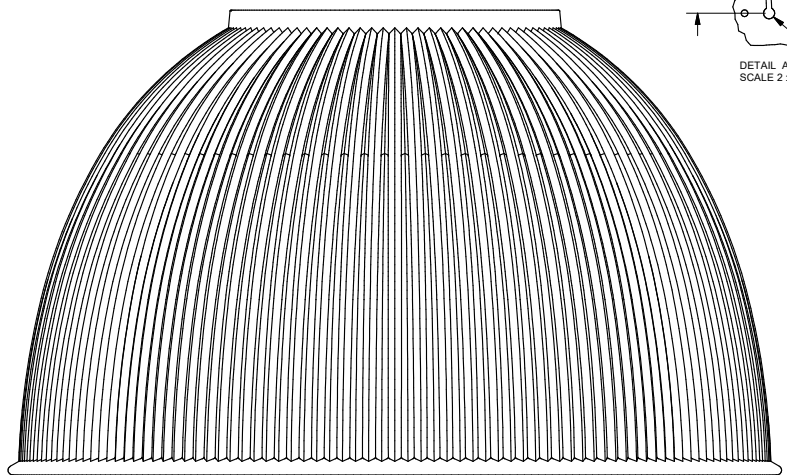
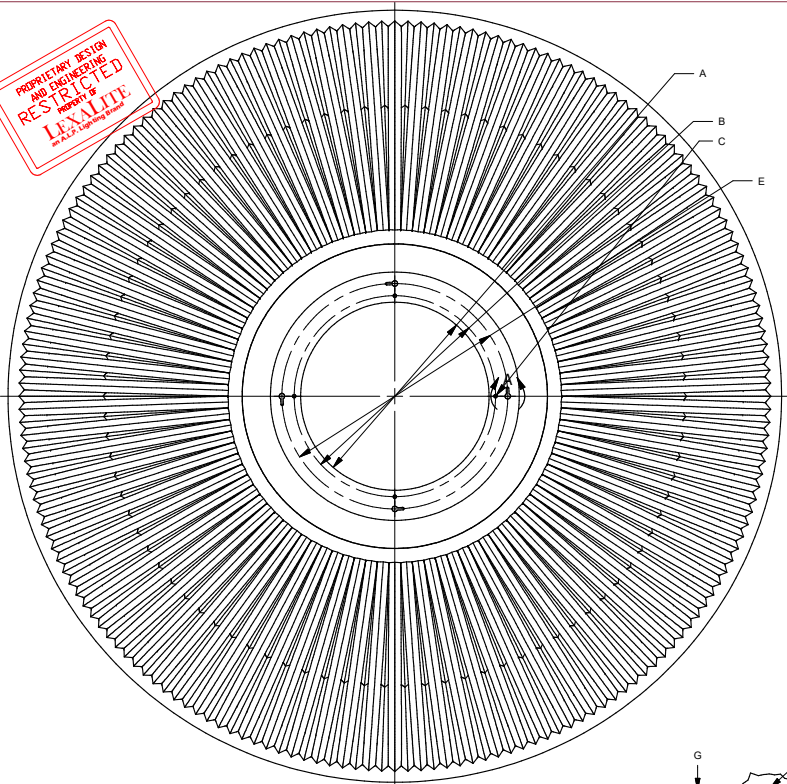

REV	EDCO	DESCRIPTION	DATE	APPROVED
A		INITIAL RELEASE	10-22-2018	RCOII
B	899	Added moon glow as a material option	2/19/2019	RCOII

CUSTOM CUT MAX FEATURE DIM 4.907"		
ITEM	DESCRIPTION	VALUE
A	HOLE DIA.	
B	BOLT CIRCLE DIA.	
C	HOLE DIA.	
D	# OF HOLES ON BOLT CIRCLE EQ. SPACED	
E	KEYHOLE BOLT CIRCLE DIAMETER	
F	LARGE KEYHOLE DIA. CLEARANCE FOR BOLT HEAD OR WASHERS	
G	ARC LENGTH OR ANGLE	
H	SMALL KEYHOLE DIA. CLEARANCE FOR THREADS	
I	# OF KEYHOLES ON KEYHOLE BOLT CIRCLE EQ. SPACED	
J	MATERIAL AC PC LUMIEO INTERFACE Moon Glow	
	CUSTOM SEE ATTACHED DWG	LIST DWG NAME AND REVISION
	COMPANY NAME	YOUR COMPANY NAME
	NAME	NAME OF PERSON FILLING OUT FORM
	SIGNATURE	AUTHORIZED SIGNATURE
	DATE	DATE COMPLETED

NOTES:
 1. UNLESS OTHERWISE NOTED;
 ALL DIMS. ARE INCHES

A.L.P.

 THIRD ANGLE PROJECTION	PROPERTIES TYPE: Generic FINISH: N/A	DRAWN BY: RayOsler DATE: 10/22/2018 CHECKED BY: Joel Robinson DATE: 10/22/2018	DESCRIPTION: 812 Order Sheet
	DRAWING FILENAME: 812 Order Sheet.idw MODEL FILENAME: 812 ORDER SHEET.ipt	TOLERANCES UNLESS SPECIFIED IN: X.X .03 X.XX .03 X.XXX .015 X.XXXX .005 ANGLES .5	STATUS: Released
-ALL PERFORATED HOLES 90.000° -SEND RADIUS 4.000° UNLESS OTHERWISE SPECIFIED -SURF CANNOT EXCEED 10% OF MATERIAL THICKNESS -ALL DIMENSIONS MUST BE VERIFIED ON THE FIRST PIECE	NOTICE: THIS DRAWING AND THE INFORMATION IT DISCLOSES IS THE EXCLUSIVE PROPERTY OF A.L.P. ANY REPRODUCTION OR USE OF THIS DRAWING IN WHOLE OR IN PART, WITHOUT THE EXPRESS CONSENT OF THE PROPRIETOR, IS PROHIBITED.	DWG NO: ORDER SHEET	REV: B