



Model 425 Tyoe V

## General Description

A.L.P. Lexalite® the Lindy® Model 425 refractor features a traditional turn-of-the-century shape and provides state-of-the-art performance. The refractor is 15.5" in diameter, 14.33" high.

## Features and Benefits

- Rated up to 250watts
- Choice of No LiteLid®, a perforated LiteLid® (enough upward light for a pleasing glow) or a non-perforated LiteLids® (no upward light in lighting fixture). Both decrease upward light 30-40% and increases downlight by 20-25%
- 401 Lineman Top configurations are now compatible with 425 Lindy Bottom.
- Available in Type III which provides roadway and parking area lighting and Type V symmetrical lighting.
- Available in UV stabilized Acrylic in Clear or Lumieo™ (for greater diffusion) for high efficiency in general lighting.
- Clear Polycarbonate options for areas where breakage and high ambient heat are concerns.

## Application

The Lindy Model 425 refractor is for use in parks, along roadways or areas where a distinctive nostalgic theme is prevalent. Compatible with HID and LED lamp sources and poles with the height of 10' to 20'.

Before final installation, dissipate static on parts by spraying with de-staticized air or by wiping with a clean damp rag. This will help minimize dust build up.

## Service Life

The service life of acrylic refractors is virtually unlimited when used within the recommended temperature limit. Polycarbonate refractors are subject to yellowing especially when used with high ultraviolet output light sources; this effect is enhanced at high temperatures.

## Ordering Information

Please call 877-257-5841 for pricing and delivery.

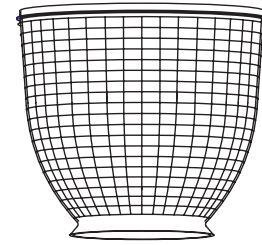

## Dimensions

14.33" Height  
15.5" diameter  
8" or 9" fitters

## Materials

Acrylic:  
Clear  
Lumieo™  
Polycarbonate:  
Clear

## Accessories/Options

Perforated LiteLid®  
Non-Perforated LiteLid®  
Aluminum Neck Ring  
Lineman™ 401 Top/Cap  
Finial

## Type III Fixture Performance for Reference Only

**Report Number:** ITL48839  
**Total Luminaire Efficiency:** 83.01%  
**IES Classification:** Type III, medium, non-cutoff

Tested in accordance with IES standards. Photometry based on a 175W phosphor-coated, metal halide lamp

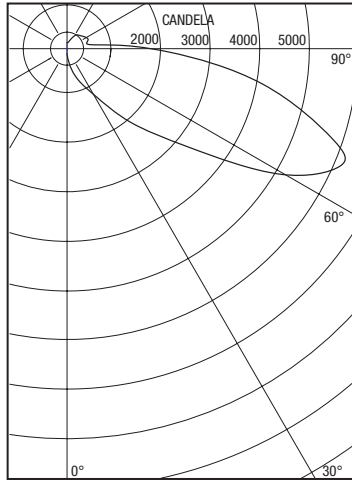

## Type V Fixture Performance for Reference Only

**Report Number:** ITL48840  
**Total Luminaire Efficiency:** 83.17%  
**IES Classification:** Type V, non-cutoff

Tested in accordance with IES standards. Photometry based on a 175W phosphor-coated, metal halide lamp

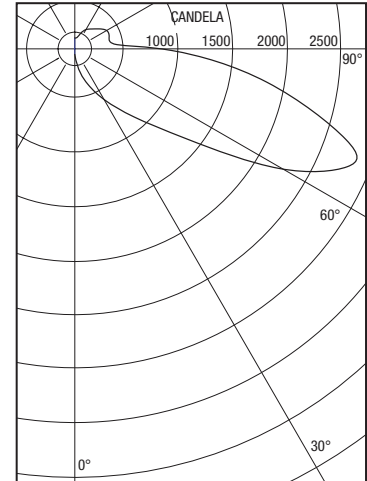

### Materials

See the LexaLite® brand price list for current part numbers and material offerings. Up-to-date and detailed material specifications can be found in the Resources section on our website [www.alpadvantage.com](http://www.alpadvantage.com).

When using an acrylic Model 425, the surface temperature of the refractor should not exceed 80°C. When using a polycarbonate Model 425, the surface temperature of the refractor should not exceed 90°C.

Note: A.L.P. does not recommend assembling acrylic 401 tops with the 425 polycarbonate bottoms due to the difference in material shrink rates, which may cause the parts to not snap together correctly.

### Notice

A.L.P. assumes no responsibility for suitability of these materials in any luminaire or application. Please test for fit and function prior to ordering project quantities.

While A.L.P. utilizes IESNA testing procedures and believes our testing results to be accurate, A.L.P. provides photometry for reference only. Actual results will vary based on the actual light source(s) and power source(s) used, i.e. ballast, driver generator, etc. and the combinations in which they are used, as well as operating temperatures, and other electrical and environmental variables. We urge that customers perform their own fixture qualifications prior to making performance based claims. In no event will A.L.P. be liable for any loss, damage, including without limitation, indirect or consequential loss or damage in connection with the use of this information.

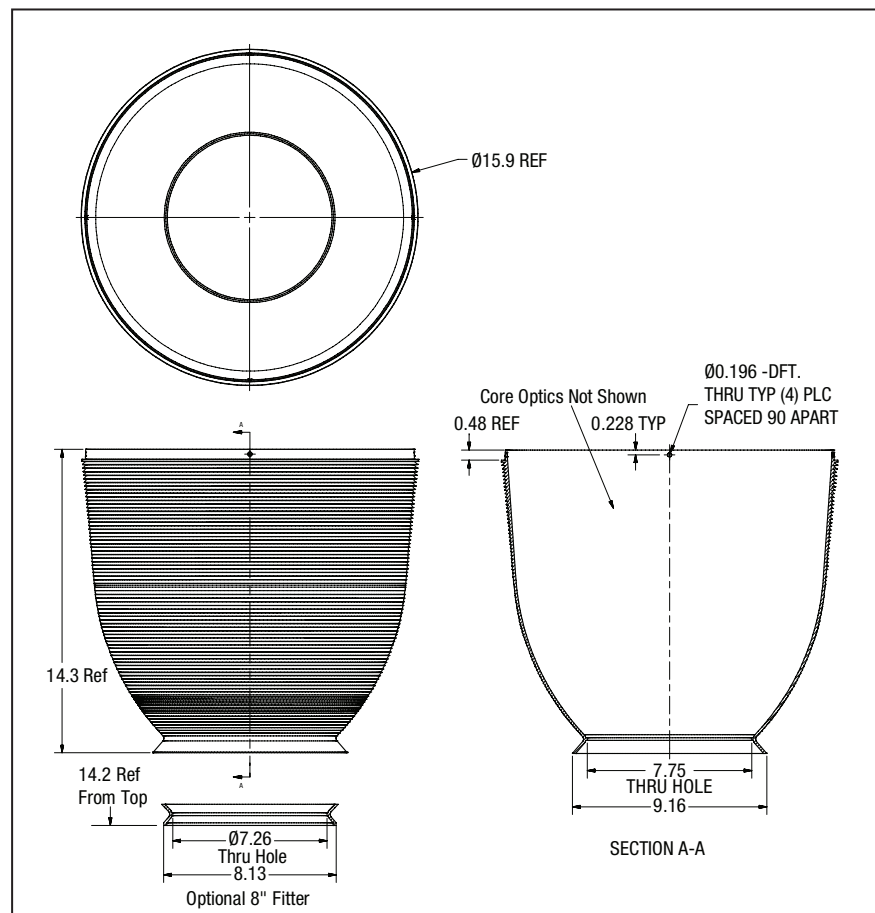

*These drawings are for reference only. Actual part dimensions will vary. Customer is urged to review actual samples to confirm fit and function. All specifications and dimensions are subject to change without notice.*