

An easily assembled cold rolled steel door frame for use with EL Series housings.

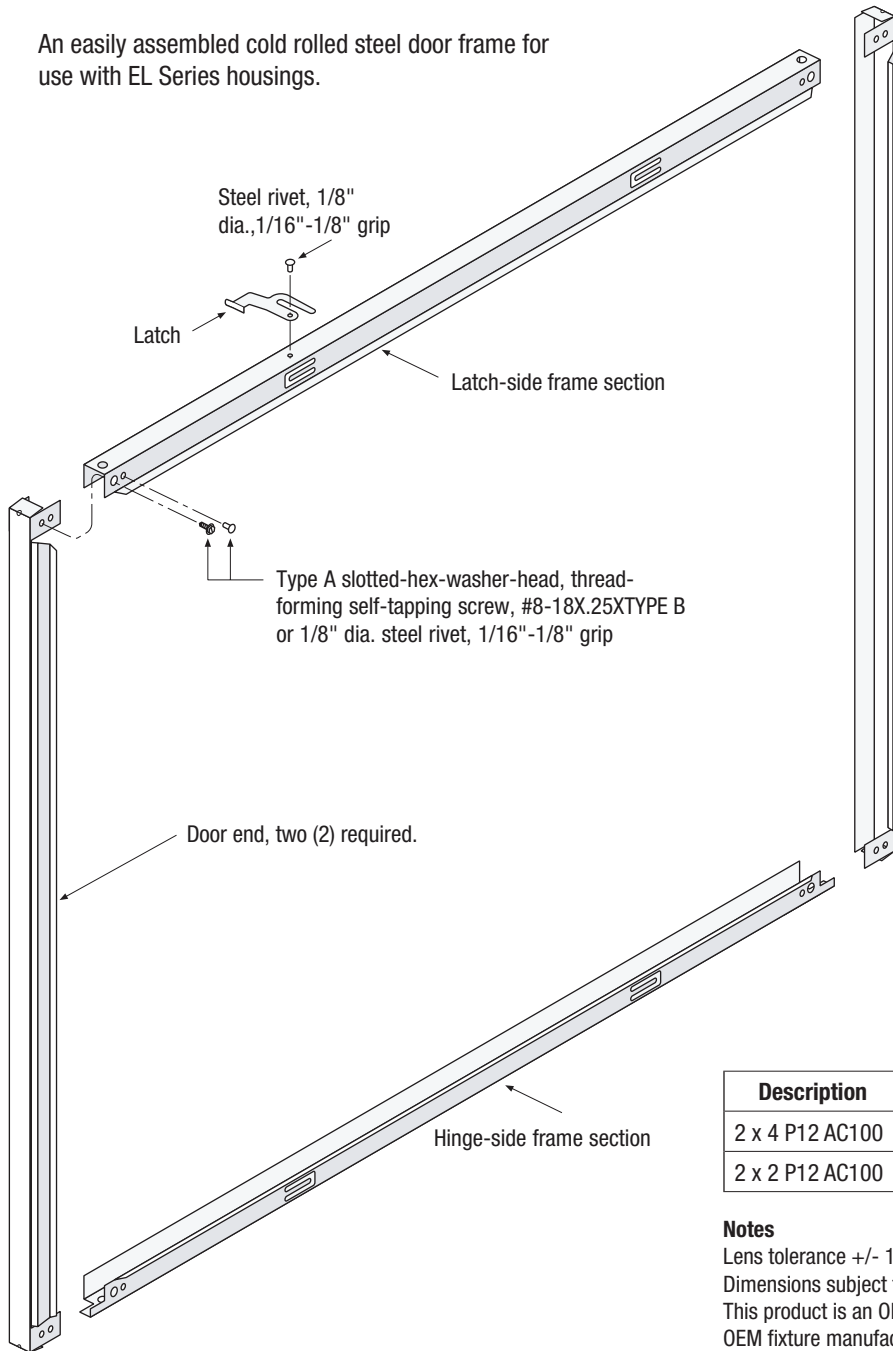

Door Frames

Catalog Number	Lens Size
EL-1x2-DOOR	10-1/2" x 22-1/2"
EL-1x4-DOOR	10-1/2" x 46-5/8"
EL-2x2-DOOR	22-1/2" x 22-1/2"
EL-2x4-DOOR	22-1/2" x 46-5/8"

Lenses

Description	Dimensions	Carton	Pallet
2 x 4 P12 AC100	22-1/2" x 46-5/8"	120215 (30)	120214 (300)
2 x 2 P12 AC100	22-1/2" x 22-1/2"	128214 (60)	128213 (600)

Notes

Lens tolerance +/- 1/16".

Dimensions subject to change without notice.

This product is an OEM Component Kit requiring final assembly by a qualified OEM fixture manufacturer.

Finish

Pre-painted white polyester polymer with minimum 82% reflectivity