

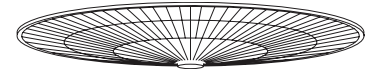

Model 16CDL



### Dimensions

16" diameter lens

### Materials

Acrylic:

Clear

Moon Glow™

Lumieo™

Polycarbonate:

Clear

### General Description

The Model 16CDL is a 16" conical drop lens designed to mount directly to the S16 and 816 Reflexor®.

### Features and Benefits

- Adding a conical drop lens to a Reflexor aids in hiding the lamp/light source
- LED sources help with widening the light distribution pattern for greater spacing criterion and vertical illuminance
- HID sources allow use of general lamps up to 250 watts

### Applications

The Model 16CDL is designed to be used in industrial, warehouse, athletic facility, agriculture processing, indoor horticulture, natatorium and retail spaces requiring better, wider illuminance and greater spacing of fixtures. The AC-FC lens is recommended for LED applications and the AC-LG lens for HID applications.

Before final installation of Reflexors, dissipate static on parts by spraying with de-staticized air or by wiping with a clean, damp rag. This will help minimize dust build up on the Reflexor.

### Service Life

The service life of acrylic refractors is virtually unlimited when used within the recommended temperature limit. Polycarbonate refractors are subject to yellowing especially when used with high ultraviolet output light sources; this effect is enhanced at high temperatures.

### Ordering Information

Please call 877-257-5841 for pricing and delivery.

### Fixture Performance for Reference Only

**Issue Date:** 7/29/16  
**Prepared For:** A.L.P. Lexalite® Brand  
**Catalog Number:** 16CDL Prismatic Reflexor®  
**Luminaire:** Generic LED  
**Lamp:** Cree LED Board of 68 LEDs  
**Mounting:** Pendant  
**Driver:** Inventronics EUD-200S070DT  
**Watts:** 157.0  
**Lumens per Watt:** 103.57

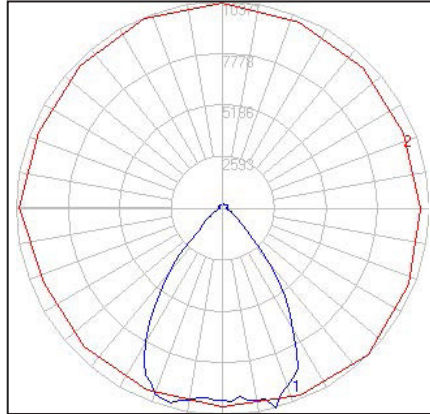

### Lumen Summary

Zone	Lumens	% Fixture
0-30	7899.13	48.58
0-40	11462.17	70.49
0-60	13906.82	85.53
0-90	14880.29	91.51
90-110	465.35	2.86
90-130	914.67	5.63
90-150	1232.65	7.58
90-180	1380.07	8.49
0-180	16260.36	100.00

### Materials

See the Lexalite® brand price list for current part numbers and material offerings. Up-to-date and detailed material specifications can be found in the Resources section on our website [www.alpadvantage.com](http://www.alpadvantage.com).

When using acrylic, the surface temperature of the lens should not exceed 80°C. When using polycarbonate, the surface temperature of the lens should not exceed 90°C.

### Notice

A.L.P. assumes no responsibility for suitability of these materials in any luminaire or application. Please test for fit and function prior to ordering project quantities.

While A.L.P. utilizes IESNA testing procedures and believes our testing results to be accurate, A.L.P. provides photometry for reference only. Actual results will vary based on the actual light source(s) and power source(s) used, i.e. ballast, driver generator, etc. and the combinations in which they are used, as well as operating temperatures, and other electrical and environmental variables. We urge that customers perform their own fixture qualifications prior to making performance based claims. In no event will A.L.P. be liable for any loss, damage, including without limitation, indirect or consequential loss or damage in connection with the use of this information.

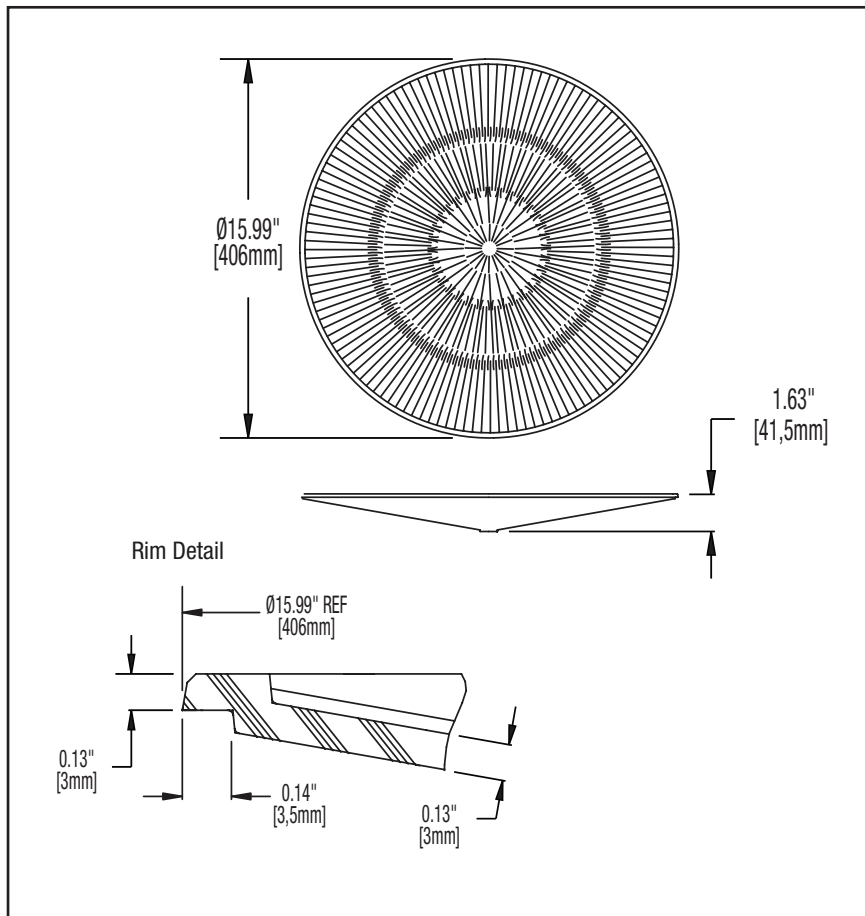

*This drawing is for reference only. Actual part dimensions will vary. Customer is urged to review actual samples to confirm fit and function. All specifications and dimensions are subject to change without notice.*