

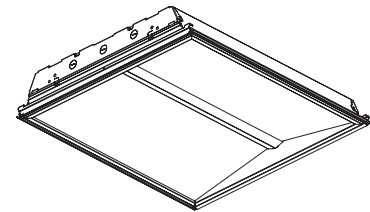

Date	
Catalog Number	
Project	
Prepared by	
Type	
Comments	



General Description

The ELNV offers the look and feel of a fluorescent luminaire — subtle soft direct elements, interest and depth across the ceiling plane — with a contemporary look that blends with today's commercial spaces.

The frosted acrylic lens provides a diffused luminance, with the effective combination of excellent light transmission and haze.

Applications

For recessed commercial applications such as offices, hospitals, schools etc. Suitable for use in standard 15/16" inverted T-Bar grid ceilings.

Features and Benefits

- Lumieo® acrylic diffuser manages the balance of efficiency and aesthetics
- Linear arrayed LED modules provide diffused, but effective illumination

Housing

Low profile troffer body with white enamel finish

Direct Optical Component

High performance optical engine

Diffuser Surround

Lumieo® acrylic diffuser center "V" adds character to the optical assembly

Luminaire Type

Recessed troffer fixture body assembly
2'x2' and 2'x4' size

Finish

Pre-painted white polyester polymer with minimum 82% reflectivity

Please contact A.L.P. for pricing and delivery.

A.L.P. will support design and development with customer supplied light engines.

All specifications subject to change without notice. A.L.P. Lighting Components, Inc. assumes no responsibility for these materials in any luminaire or application.

The product is an OEM component kit requiring final assembly by a qualified OEM fixture manufacturer.

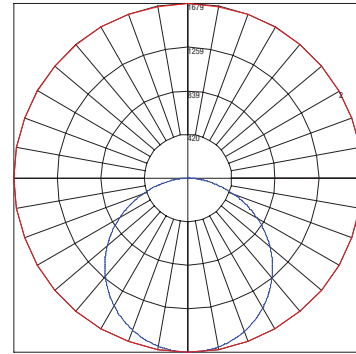
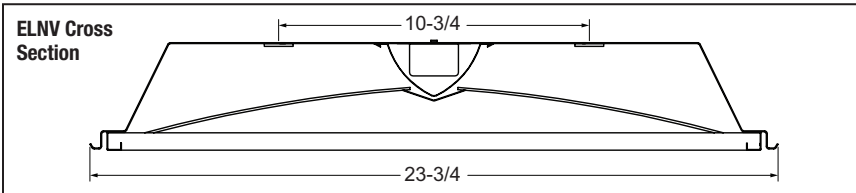

Report Number:

s15070025s-01

Test Date: 07/29/15

Product Number:

ELNV24-4850-1

Lumens: 4713.9

Watts: 48

Lumens Per Watt: 98

CRI: 80

CCT: 3500K

Zonal Lumen Summary

Zone	Lumens	%Fixt
0-30	1295.61	27.50
0-40	2115.92	44.90
0-60	3728.13	78.10
0-90	4708.3	99.90
0-180	4713.94	100.0

Spacing Criteria

0-180	1.28
90-270	1.22
DIA	1.38

ELNV Exploded Assembly

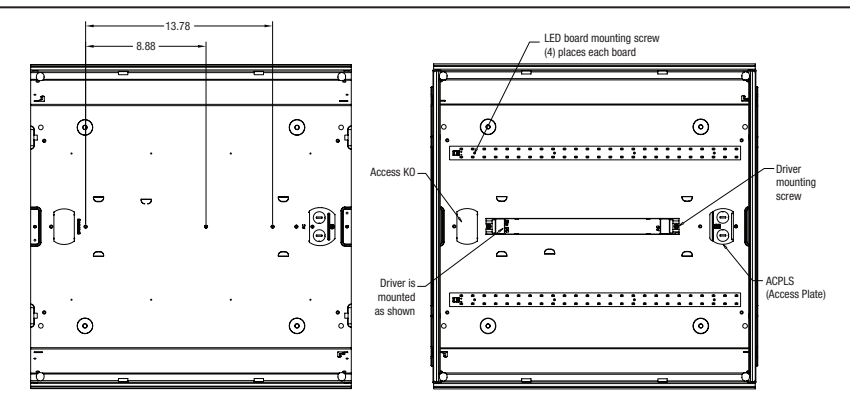
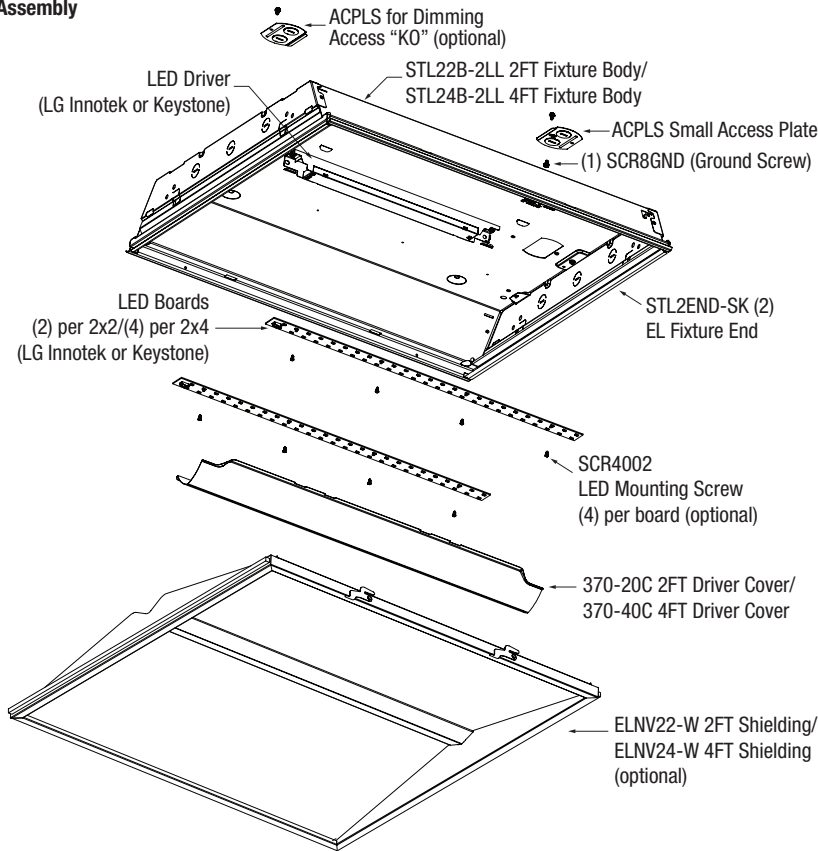

ELNV Metal Component Kits		
Kit Number	Component	Qty
EL-2x2-2LL		
STL22B-2LL	2ft LED Body	1
370-20C	2ft Cover	1
STL2END-SK	2ft End	2
ACPLS	Small Access Plate White	1
EL-2x4-2LL		
STL24B-2LL	4ft Shallow LED Body	1
370-40C	4ft Cover	1
STL2END-SK	2ft End	2
ACPLS	Small Access Plate White	1

Shielding Options		
Part Number	Description	Qty
ELNV22-W	ELNV 2x2 Door White	1
ELNV24-W	ELNV 2x4 Door White	1

Optional Hardware	
Part Number	Description
SCR8001	#8-18X.25XTYPE B, Hex/Slot/Phil
RIV41431W	D41-43BS MULTI Grip Rivet White
SCR8GND	#8-32X1/4 Slot/Hex Green Zinc
SCR4002	#4-40x3/16 Phil Pan Zinc Thread Cut Screw, LED