

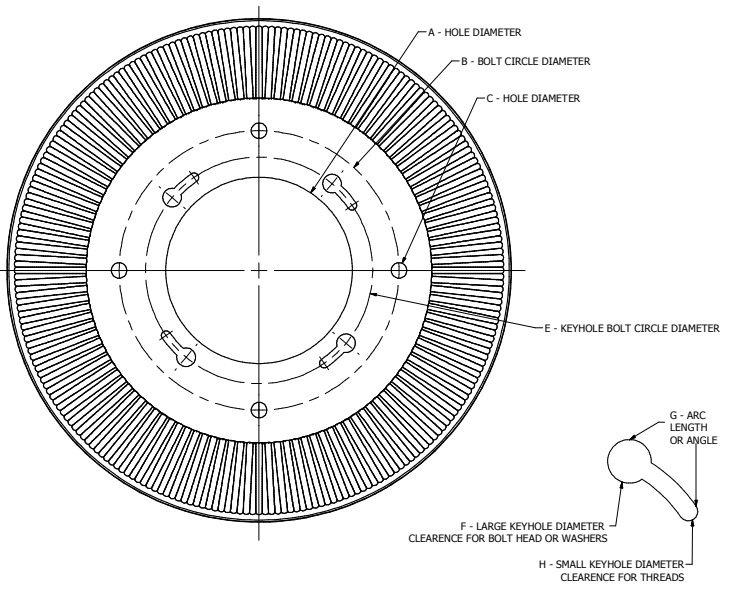

REVISION HISTORY			DESCRIPTION	CNG ENG
REV	DATE	EDCO		
A	1/9/2015	NA	RELEASED	KAW
B	6/10/2015	622	ADD NOTE 6	RDTII
C	10/15/2015	644	ADDED PART NUMBER BOX	BRF
D	11/23/2015	658	EDITED PART NUMBER BOX	BRF
E	5/9/2016	722	ADDED METALIZING TABLE	BRF
F	7/12/2016	746	ADDED KEYHOLE BOLT CIRCLE AND QUANTITY BOXES	BRF
G	1/19/2017	796	Change max custom cut hole opening from 10.06 to 10.66	RCOII
H	3/6/2017	803	CHANGE VERBAGE TO MAX FEATURE DIM	RCOII
I	2/17/2019	893	ADDED MOON GLOW TO MATERIAL OPTIONS	RCOII



**CUSTOM CUT MAX FEATURE DIM 10.66"**

ITEM	DESCRIPTION	VALUE
A	HOLE DIA.	
B	BOLT CIRCLE DIA.	
C	HOLE DIA.	
D	# OF HOLES ON BOLT CIRCLE EQ. SPACED	
E	KEYHOLE BOLT CIRCLE DIAMETER	
F	LARGE KEYHOLE DIA.	
G	ARC LENGTH OR ANGLE	
H	SMALL KEYHOLE DIA.	
I	# OF KEYHOLES ON BOLT CIRCLE EQ. SPACED	
CUSTOM SEE ATTACHED DWG COMPANY NAME		LIST DWG NAME AND REVISION
NAME		YOUR COMPANY NAME
SIGNATURE		NAME OF PERSON FILLING OUT FORM
DATE		AUTHORIZED SIGNATURE
		DATE COMPLETED

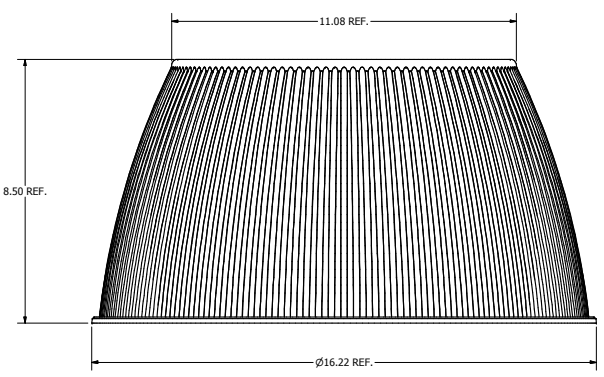

**NOTES:**

- UNLESS OTHERWISE NOTED; ALL DIMS. ARE INCHES
- TOLERANCES: .xxx ± 0.032
- PLEASE COMPLETE SUPPLIED TABLE FOR CUSTOM CUT TOPS.
- FEATURES SMALLER THAN Ø0.130" WILL REQUIRE LASER CUTTING.
- IF NEEDS FALL OUTSIDE SUPPLIED TABLE PLEASE PROVIDE DRAWING.
- A.L.P. LIGHTING COMPONENTS INC. RECOMMENDS A LOAD BEARING COLLAR OR WASHER BE USED AROUND FASTENERS

METALIZING		
OPTIONS	YES	NO
WHITE POLYCARBONATE ONLY		

MATERIALS	
OPTIONS	YES / NO
AC	
MOON GLOW	
PC	
LUMIEO	
INTERFACE	

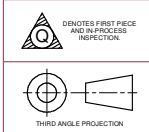

**LEXALITE**  
An A.L.P. Brand

PROPERTIES: MATERIAL: N/A BASEWALL: FINISH: VOLUME: N/A AREA: N/A DRAWING FILENAME: S16 ORDER SHEET.dwg MODEL FILENAME: S16 ORDER SHEET.ipt	DRAWN BY: K.A. WILSON DATE: 1/9/2015 CHECKED BY: J.E. ROBINSON DATE: 1/9/2015 DESCRIPTION: S16 ORDER SHEET TOLERANCES UNLESS SPECIFIED: X.X X.XX X.XXX X.XXXX STATUS: Released DO NOT SCALE DRAWING SHEET 1 OF 1 DWG NO: 3838 REV: 1
--	---